



THEORETICAL BACKGROUND FOR INCREASING GRIP PROPERTIES OF WHEELED TRACTORS BASED ON THEIR RATIONAL BALLASTING

Volodymyr Bulgakov¹, Volodymyr Nadykto², Serhiy Kyurchev², Viktor Nesvidomin¹, Semjons Ivanovs³, Jüri Olt⁴

¹National University of Life and Environmental Sciences of Ukraine, Ukraine, 15 Heroyiv Oborony Str., UA 03041 Kyiv, Ukraine

²Tavria State Agrotechnological University, 18B, Khmelnytsky Ave, UA72310 Melitopol, Zaporozhye Region, Ukraine

³Latvia University of Life Sciences and Technologies, 2 Liela Street, LV-3001 Jelgava, Latvia

⁴Estonian University of Life Sciences, Institute of Technology, 56 Kreutzwaldi, 51006 Tartu, Estonia

Saabunud: 30.07.2019
Received:
Aktsepteeritud: 07.10.2019
Accepted:

Avaldatud veebis: 15.10.2019
Published online:

Vastutav autor: Jüri Olt
Corresponding author:
E-mail: jyri.olt@emu.ee

Keywords: tractor, ballast, wheel load, tire.

doi: 10.15159/jas.19.07

ABSTRACT. The correct selection of the level of mechanical ballasting for wheeled tractors is among the most important issues for increasing their utilisation efficiency, in particular, increasing their grip properties. The shortcoming of the earlier undertaken investigations was that they virtually did not take into account the allowed maximum pressure of the tractor's wheels on the soil. At the same time, little attention was paid to the impact of the maximum load-carrying capacity of the wheel tyres. The aim of the paper is to eliminate these deficiencies. Because of the authors' efforts, the new technique has been developed, which differs in that it employs the requirement of the tyre's ecofilic properties. The implementation of this requirement implies setting the maximum allowed level of the tractor wheels' pressure on the soil and taking into account the maximum load-carrying capacity of the wheel tyres as well as the vertically applied load on each of the tractor's axes under the simultaneous action of both the horizontal and vertical components of the tractive resistance of the employed agricultural implement. The practical effectiveness of the new approach is shown by the example of determining the possibility and level of ballasting the specific wheeled tractor operating as part of a ploughing unit.

© 2019 Akadeemiline Põllumajanduse Selts. | © 2019 Estonian Academic Agricultural Society.

Introduction

Recently, the scientists and practical experts have been more and more opting for tractor ballasting as a way of solving the problem of the efficient operation of agricultural machinery. This approach is based on the assumption that increasing the tractor's operating weight facilitates the improvement of its grip properties. At the same time, the reduction of the specific fuel consumption takes place (Spagnolo *et al.*, 2012; Lovarelli *et al.*, 2018).

However, if until recently the recommended level of tractor ballasting had stayed within the range of 0–23% of the tractor's operating weight, now many companies go for levels of 100% and even more (Boykov, Belkovskiy, 1988; Bulgakov *et al.*, 2016). That means that, in principle, some tractors can be ballasted with weights that are equal or exceeding their operating weights.

However, it has to be remembered that the greater the vertical load per tractor wheel tyre is, the higher the soil compaction rate is (Ansorge, Godwin, 2007). Moreover, this effect is quite pronounced not only in the upper soil layer but in the lower stratum as well (Taghavifar, Mardani, 2014). That note is of great importance since the soil compaction rate is much easier to control in the upper soil layer, than in the lower one.

The operators of agricultural machinery have to keep in mind that the ballasting weight must be correctly distributed between the tractor's axles. Otherwise, the traction efficiency of the tractor will inevitably become reduced, together with the agronomic background becoming substantially compacted (Pranav, Pandey, 2008; Nadykto *et al.*, 2015).

In general, the draught resistance of the employed agricultural implements shapes the distribution of the vertical load between the tractor's axles. In order to



reduce or even exclude its impact on the tractor operating in the transportation mode, the scientists have drawn the respective theoretical functional relations (Janulevičius, Giedra, 2005). However, since the paper scrutinises only the transport unit, the draught resistance of the towed implement is represented only by the horizontal component.

Moreover, the same research group have derived the equations that facilitate calculating the masses of the ballast loads needed to provide for the controlled movement of the tractor with the attached implements (Janulevičius, Giedra, 2008). Again, the vertical component of their resistance is not taken into consideration. Meanwhile, the practical experience of operating agricultural units has proved that its input in the distribution of the vertical loads between the tractor's axles is more significant than that of the horizontal component (Bulgakov *et al.*, 2016).

However, the most important omission in the earlier undertaken studies is that they do not include into the scope of consideration of the tractor-ballasting problem the maximum permissible pressure of its wheels on the soil (Wong, Huang, 2006; Šmerda, Čupera, 2010). In addition, the maximum load-bearing capacity of the wheel tyres is paid insufficiently much attention. Whereas omitting these parameters from consideration can result in the tractor ballasting becoming either insignificant or even completely impossible, even in case double (or triple) tyres are used. Moreover, this fact is crucial, since the issue of preserving the structure, which means the fertility, of the soil, is day after day becoming more urgent.

It is also worth noticing that the technique of theoretically determining the vertical loads on the tractor axles in the presence of the horizontal and vertical components of the tractive resistance of the operated agricultural implements (especially the tractor-mounted ones!) has been highlighted inadequately little in the scientific publications.

In this context, the aim of the paper is to develop such a technique for determining the tractor ballasting conditions, which will take into account: a) level of the maximum permissible pressure of the tractor's wheels on the soil; b) maximum load-bearing capacity of the wheel tyres; c) vertical load on each of the tractor's axles, when the tractor is under the action of both the horizontal and vertical components of the draught resistance of the operated agricultural implement.

Theoretical premises

It is common knowledge that the ballasting of a wheeled tractor is most effective on hard surfaces, while it happens exactly on soft backgrounds that need in ballasting arises (Guskov *et al.*, 1988; Nadykto *et al.*, 2015). In addition, the latter ones are more prone to such a negative process as soil compaction, especially in the early spring season.

Hence, the **first requirement** is defined as follows: the pressure on the soil generated by the tractor's wheels may not exceed the maximum permissible value

$[Q_r]$.

The **second requirement** is as follows: the operating vertical load on the wheel N_{ek} may not exceed the maximum load-bearing capacity of the tyre P_w . Merging the two above-stated requirements, the following condition of the wheel tyre's **ecofilic property** recommended by the authors is arrived at:

$$\frac{N_{ek} \leq P_w}{F_s} \leq [Q_r], \tag{1}$$

where F_s – area of the tyre's supporting (ground contact) surface.

The parameter F_s can be calculated with a practically sufficient accuracy using the following relation:

$$F_s = \pi \cdot H_z \cdot \sqrt{(D - H_z) - (B - H_z)}, \tag{2}$$

where H_z – depth of the tread generated by the wheel; D , B – diameter of the wheel and width of its tyre, respectively. In its turn:

$$H_z = \frac{N_{ek}}{\pi \cdot \rho_w} \cdot \sqrt{D \cdot B}, \tag{3}$$

where ρ_w – pressure of the air in the wheel tyre.

From the expression (1), the following condition of the possibility to ballast the tractor's wheel results univalent:

$$\frac{N_{ek} < P_w}{F_s} < [Q_r]. \tag{4}$$

Therewith, when the condition (4) is fulfilled in practice, the ballast weight per tractor wheel can be determined with the use of the following formula:

$$M_b = (P_w - N_{ek}) / g, \tag{5}$$

where g – free-fall acceleration.

In its general form, the process of determining the possibility to ballast some specific wheeled tractor (in terms of one wheel) has the following simple algorithm (Figure 1).

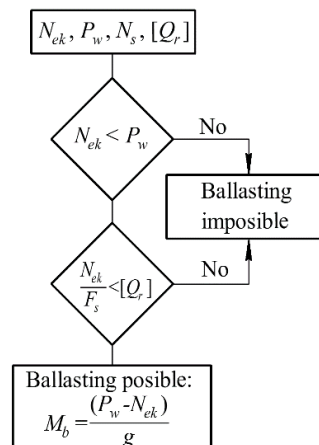

Figure 1. Flow chart of algorithm for determining possibility of tractor ballasting

In the formulae (4) and (5), the parameter N_{ek} – operating vertical load per wheel of the tractor, is an unknown quantity. In order to develop the method of its theoretical determination, an equivalent schematic model of the forces acting on the tractor with the mounted implement in the longitudinal and vertical plane will be analysed.

The first step is to examine the force system acting only on the tractor. For that purpose, the respective mechanical constraints will be replaced by their reactions. On the part of the mounted implement, the forces acting on the tractor are R_{zn} and R_{zv} (Figure 2).

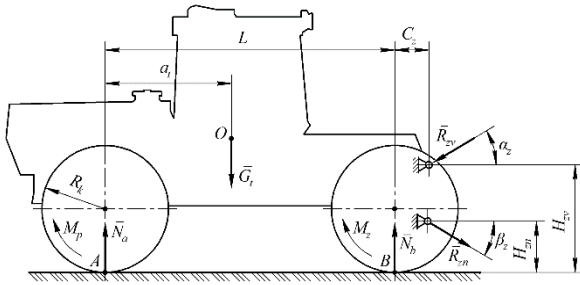

Figure 2. Equivalent circuit of forces influencing on the tractor

The first of the mentioned forces acts on the tractor via the top link, the second one – via the lower links of its rear linkage. Together with the tractor's weight force G_t , they generate the vertical reactions on the wheels of its front (N_a) and rear (N_b) axles.

That said, the following should be kept in mind. The tangential traction forces of the tractor axles and the respective forces of resistance to their movement are applied at points A and B and vectored strictly horizontally. In view of that, they are not used in the equations for determining the reactions (N_a) and (N_b), therefore, they are not shown in Figure 2.

The mounted implement is under the action of (Figure 3): a) reaction from the tractor R_{zn} and R_{zv} ; b) implement weight force G_p ; c) vertical reaction of the implement's carrier wheel N_k ; d) force P_{fk} and moment M_{fk} of implement carrier wheel rolling resistance; e) vertical (R_z) and horizontal (R_x) components of the implement's draught resistance applied at point D.

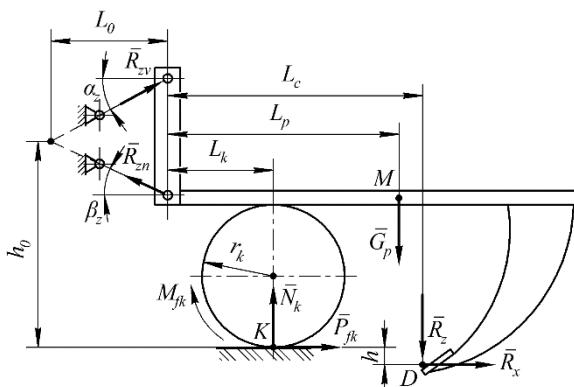

Figure 3. Equivalent circuit of forces influencing on the agricultural implement

For the combination of the tractor and the mounted implement (Figure 2 and Figure 3), the following five forces are unknown quantities: N_a , N_b , N_k , R_{zv} , R_{zn} . In order to determine them, it is sufficient to have five independent equations of the tractor and implement equilibrium in the longitudinal and vertical plane.

The above-mentioned equations appear as follows:

$$\begin{aligned} N_a - G_t + N_b - R_{zv} \cdot \sin \alpha_z - R_{zn} \cdot \sin \beta_z &= 0; \\ G_t \cdot a_t - N_b \cdot L + f \cdot R_k (N_a + N_b) + R_{zv} \cdot K_1 + R_{zn} \cdot K_2 &= 0; \\ N_k - G_p - 0.2 \cdot R_x + R_{zv} \cdot \sin \alpha_z + R_{zn} \cdot \sin \beta_z &= 0; \\ f \cdot N_k + R_x + R_{zv} \cdot \cos \alpha_z - R_{zn} \cdot \cos \beta_z &= 0; \\ R_x \cdot [0.2(L_c + L_0) - h_0 - h] + N_k \cdot (f \cdot r_k - L_k - L_0 - f \cdot h_0) + G_p \cdot (L_p + L_0) &= 0, \end{aligned} \quad (6)$$

where

$$\begin{aligned} K_1 &= -\cos \alpha_z \cdot H_{zv} + \sin \alpha_z \cdot (C_z + L); \\ K_2 &= \cos \beta_z \cdot H_{zn} + \sin \beta_z \cdot (C_z + L); \\ L_0 &= \frac{H_{zv} - H_{zn} + l_{zn} \cdot (\tan \alpha_z \cdot \cos \beta_z + \sin \beta_z)}{\tan \alpha_z + \tan \beta_z}; \\ h_0 &= L_0 \cdot \tan \beta_z + H_{zn} - l_{zn} \cdot \sin \beta_z. \end{aligned}$$

In the system of equations (6), f – coefficient of rolling resistance; α_z , β_z – angles of inclination with respect to the horizontal plane of the central and lower links of the tractor's linkage, respectively; l_{zn} – length of the lower links of the tractor's linkage; a_t , L , L_c , L_0 , L_k , L_p , h_0 , h , r_k , C_z , H_{zn} , H_{zv} – parameters, the meaning of which is obvious from Figure 2 and Figure 3.

The system of equations (6) makes it rather easy to determine the vertical reactions on the tractor axles N_a and N_b . If the parameters of the tractor's tyres/wheels are known and the $[Q_r]$ has been selected, then, using the equations (4) and (5), both the possibility and level of ballasting for each of the tractor axles can be determined.

It is to be noted that the system of equations (6) can easily be transformed for the case of the tractor operated with a trailing implement. For that purpose, it will be sufficient to analyse the equilibrium state of the tractor, when the implement acts on the tractor only with the force R_{zn} , inclined at a respective angle of β_z to the horizontal (Figure 2).

Materials and Methods

The accuracy of the above-stated theoretical background was verified with the use of the ploughing unit comprising a HTZ-17221 tractor and a PLN-5-35 five-bottom force-measuring plough (Figure 4).



Figure 4. Ploughing implement on HTZ-17221 carrying tractor

Summary specification of HTZ-17221	
Operating weight force (G_t , kN)	85.4
Engine output rating (kW)	129
Tyres	23.1R26
Static load per tyre (kN):	
- front axle (N_{ast})	26.7
- rear axle (N_{bst})	16.0
Static diameter of tyre (D , m)	1.6
Width of tyre section (B , m)	0.587
Maximum load-carrying capacity of tyre (P_w , kN)	30.9
Air pressure in tractor's tyres (ρ_w , kPa)	120

The ploughing was carried out in the autumn season. In accordance with the requirements of DSTU 4521: 2006 "Mobile agricultural machinery", the maximum permissible pressure of the tractor wheels on the soil [Q_r] was assumed at 160 kPa.

The tractor weight force (G_t) and its distribution between the axles (N_{ast} , N_{bst}) as well as the plough weight force (G_p) were determined by weighing them with the use of the DPU-5 load gauge to an accuracy of 0.5 kN. The obtained resulting data were used for determining the longitudinal coordinate of the tractor's centre of mass (a_t) with the use of the following formula:

$$a_t = \frac{N_{ast} \cdot L}{G_t}, \quad (7)$$

where L – tractor's wheelbase (Figure 2). This parameter, as well as the linear parameters L_c , L_k , L_p , r_k , C_z , H_{zn} , H_{zv} and l_{zn} , were measured with the use of a gauge tape to an accuracy of 1 cm.

During the field-testing of the ploughing unit, the tractor travelled on the stubble field of winter wheat. In order to determine the coefficient of rolling resistance f , the tested tractor together with the plough were towed by another tractor. The effort applied for the translation of the ploughing unit (P_f) in the five test repetitions was registered with the use of the strain-gauge link that sent a signal to the analogue-digital converter, which transmitted it to the PC. The required unknown coefficient

was determined with the use of the following expression:

$$f = \frac{P_f}{G_t + G_p}. \quad (8)$$

The draught resistance of the plough (R_x) was measured with the use of the draught strain-gauge link installed on it (Figure 5).

The signal from that link was registered in the PC after being processed by the analogue-digital converter. The ploughing unit was set up for three different tilling depths: 22, 25 and 28 cm. The travelling velocity of the unit during its ploughing to each of the specified depths was determined on a leg with a length of 250 m in two repetitions (travelling ahead and returning). The unit travelling time t was measured to an accuracy of 0.2 s with the use of the COC-26-2-000 stopwatch. On the same leg, the effective rolling radius of the tractor wheel R_k was determined. This was done with the use of the following formula:

$$R_k = \frac{60 \cdot 250}{\pi \cdot t \cdot n_k}, \quad (9)$$

where n_k – number of the tractor wheel's revolutions. This parameter was registered with the use of hermetically sealed reed relay sensors (Figure 6).

After each run of the unit, the depth of tilling was measured with the use of a mechanical depth gauge. The measurement spacing was 1 m, the number of measurements – at least 200.

The following statistical characteristics were computed for the arrays of data on the plough draught resistance and the depth of ploughing: mean, variance, coefficient of variation, correlation function and spectral density.

The data obtained as a result of the measurements were input into the system of equations (6) in order to determine the vertical reactions on the front (N_a) and rear (N_b) axles of the tractor. Then, using the formulae (4) and (5), the possibility and level of the tractor axle ballasting were found.



Figure 5. Draught strain-gauge link



Figure 6. Wheel rpm pickup

Results and Discussion

First, the assessment is to be done of the impact of the plough's oscillations on the tractor. This assessment will take into account the fact that the more stable its traction load is, the more stable values of the vertical loads on the tractor axles are.

In their turn, the stability of the plough draught resistance oscillations (force R_x , Figure 3) is largely defined by the characteristics of the tilling depth (parameter h) oscillations.

The analysis of the experimental data has shown that the variance of this parameter's oscillations does not substantially differ for different tilling depths (Table 1). According to the F-test of Fischer, it can be stated with a confidence level of 95% that the null hypothesis of the equality of the compared variances is not rejected.

The coefficient of variation of the ploughing depth oscillations at all depth values does not exceed 6%. That indicates that the process under consideration has low variability (Dospheov, 1985). Moreover, it turns out to be also a low-frequency process. This conclusion results from the analysis of the normalized correlation functions of the ploughing depth oscillations (Figure 7).

As can be seen in the diagrams presented in Figure 7, the length of correlation for all three functions is equal to about 3.5 m. That means that this is the distance, at which the correlation between the tilling depth values disappears virtually completely. Admittedly, the said length of correlation suggests the low frequency of the process of oscillation of the depth, to which the unit under investigation ploughs the soil. Moreover, it is virtually stochastic, since the analysed normalized correlation functions do not contain any more or less pronounced periodic components.

The low variability of the ploughing depth oscillations (*i.e.* the parameter h) is reflected respectively in the characteristics of the plough draught resistance (force R_x) oscillations. As is proved by the analysis of the experimental data (Table 1), the variance of these parameter oscillations is virtually independent on the tilling depth. Again, in accordance with the F-test of Fischer, the difference between its values is statistically random. Also, since the values of the coefficient of variation stay within 10% (Table 1), the process under consideration is a low variability one (Dospheov, 1985).

The frequency spectrum of the plough draught resistance oscillations can be assessed by analysing the respective normalized spectral densities (Figure 8).

The analysis has shown that the cut-off frequency for the normalized spectral densities of the R_x force oscillations is within the range of 16–18 s^{-1} (*i.e.* 2.5–2.9 Hz) for all the three ploughing depth settings. The maximums of the plough draught resistance oscillation variances are observed within the frequency range of 0 to 6 s^{-1} , which altogether does not exceed 1 Hz. All that unequivocally indicates that the oscillations with such characteristics are low-frequency oscillations.

It is appropriate to suggest that the stable properties of the variation of the tilling depth and the plough draught resistance oscillations provide no ground for any significant oscillations of the vertical load on the tractor's axles. For the purposes of the theoretical computation, they can be assumed, to a first approximation, to be virtually constant.

Using the measurement results obtained during the experiments and the system of equations (6), the vertical loads on the front (N_a) and rear (N_b) axles of the tractor have been obtained (see Table 1). The calculations have been done with the use of the following values for the parameters in the system of equations (6):

$$G_t = 85.4 \text{ kN}; G_p = 8.4 \text{ kN}; L = 2.86 \text{ m}; f = 0.07; a_t = 1.1 \text{ m}; r_k = 0.2 \text{ m}; L_c = 1.7 \text{ m}; L_k = 1.5 \text{ m}; L_p = 1.5 \text{ m}; C_z = 0.4 \text{ m}; l_{zn} = 0.93 \text{ m}; \alpha_z = 5^\circ; \beta_z = 1^\circ; R_k = 0.78\text{--}0.80 \text{ m}; H_{zv} = 1.2 \text{ m}; H_{zn} = 0.45 \text{ m}.$$

The values of the variable parameters h and R_x are shown in Table 1. The analysis has determined that, in the presence of a draught load, considerable redistribution of the vertical loads on the tractor axles takes place. Specifically, the vertical load on the front axle decreases and on the rear axle increases. Overall, additional loading of the whole tractor takes place. The characteristic of this process is shown in Figure 9.

As is obvious, the greater the plough draught resistance is, the greater the additional vertical load on the tractor becomes, even though at an insignificant rate (by 2–3 kN). Together with the operating weight ($G_t = 85.4 \text{ kN}$), this makes up the adhesion weight of the tractor within the range of 87.4–88.4 kN.

The further calculations with the use of the formulae (4) and (5) have been carried out using the following values of their parameters: $N_{ek} = N_a$ or N_b ; $[Q_r] = 160 \text{ kPa}$; $D = 1.6 \text{ m}$; $P_w = 30.9 \text{ kN}$; $\rho_w = 120 \text{ kPa}$; $B = 0.587 \text{ m}$.

Table 1. Results of experimental and calculated data of ploughing unit

Ploughing depth h			Plough's draught resistance R_x			Calculated data	
Mean (cm)	Variance (cm ²)	Coefficient of variation (%)	Mean (kN)	Variance (kN ²)	Coefficient of variation (%)	Dynamic load N_a (kN)	Dynamic load N_b (kN)
21.9	1.65	5.9	25.0	3.50	7.5	50.4	37.0
25.7	1.73	5.1	28.4	4.00	7.0	50.6	37.2
28.5	1.88	4.8	31.8	4.60	6.7	50.8	37.4

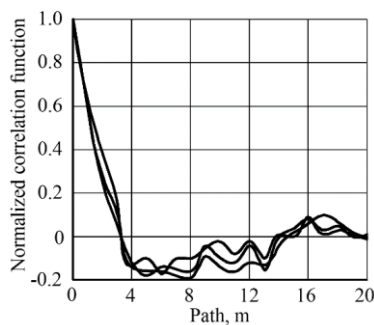

Figure 7. Normalized correlation function of ploughing depth

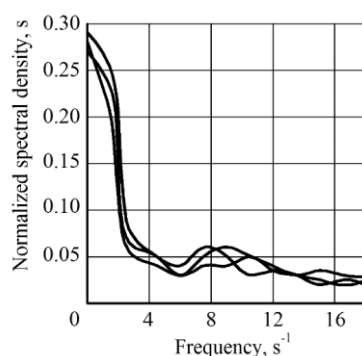

Figure 8. Normalized spectral density of plough draught resistance

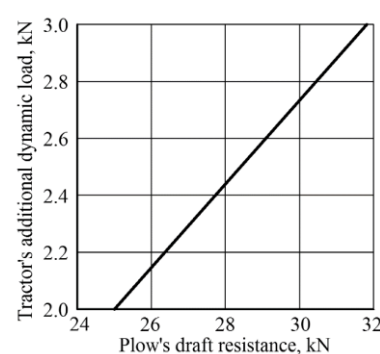

Figure 9. Tractor's additional dynamic load dependence on plough's draught resistance

The results of calculations show that the front axle of the tractor under consideration when operated with a plough, can be in principle additionally loaded with a weight at a rate of 1140 kg. However, in reality this is **not** to be done. The reason is as follows. When the tractor travels without a traction load (or stands), the vertical reaction on its front axle is $N_{ek} = 53.4$ kN. If the ballast weight equal to $(1140 \cdot 9.81)/1000 = 11.2$ kN is added to it, the resulting sum will be $N_{ek} = 53.4 + 11.2 = 64.6$ kN. However, that violates the condition (4). In accordance with the expression (5), the maximum ballast weight that can be used to load additionally the front axle of the tractor under consideration may not exceed 900 kg. However, if the maximum permissible pressure of the wheels on the soil is set at a level of $[Q_r] = 130$ kPa, then this ballasting weight (i.e. 900 kg) will also become unacceptable.

The front axle of a HTZ-17221 tractor, when operated with a plough, can be additionally loaded, as follows from formula (4), by a weight of 2500 kg. In that case, if the maximum permissible pressure of the wheels on the soil is set at $[Q_r] = 130$ kPa, the maximum permissible ballasting of the tractor will be not greater than 530 kg.

Overall, at $[Q_r] = 160$ kPa, the total ballasting weight on a HTZ-17221 tractor planned to be used with a five-bottom plough with a working width of 1.75 m may not exceed $M_b = 900 + 2,500 = 3,400$ kg. However, this value is equal to only 39% of the operating weight of the above-mentioned tractor.

At $[Q_r] = 130$ kPa, ballasting this tractor is altogether not allowed. Otherwise, that will result in both overloading the tractor's tyres and inexcusably strong compaction of the soil, the fertility of which has to be maintained at all times. Ballasting such a tractor at $[Q_r] = 130$ kPa becomes possible only in case of using twin tyres. However, that engineering solution is technologically impracticable in case of operating the HTZ-17221 tractor with a plough.

Conclusions

Improving the efficiency of operation of wheeled tractors by means of increasing their grip properties can be achieved through the correct selection of the level of their mechanical ballasting. When solving the problem

of ballasting wheeled tractors, it is suggested to take as the basis the new condition of the ecofilic property of the tyre. The devised technique of the practical implementation of this condition implies: 1) deciding on (setting) the maximum permissible pressure of the tractor wheels on the soil; 2) taking into account the maximum load-carrying capacity of the wheel tyres of the specific tractor; 3) finding out / taking into account the real values of the vertical loads on each of the tractor axles, when both the horizontal and vertical components of the draught resistance of the operated agricultural implement act on the tractor.

The specific example of application of the devised technique has revealed that, when a tractor with an operating weight of about 8700 kg and the maximum permissible pressure of the wheels on the soil of 160 kPa unitised with a plough with a working width of 1.75 m is used, the maximum permissible level of ballast on the engine unit may not exceed 39% of its weight. If the permissible pressure of the wheels on the soil is set at $[Q_r] = 130$ kPa, ballasting the tractor under consideration is altogether not allowed.

Conflict of interest

The authors declare that there is no conflict of interest regarding the publication of this paper.

Author contributions

VB – study conception and design;
VN, SK, VN, JO and SI – acquisition of data;
VN and VN – analysis and interpretation of data;
VB and JO – drafting of the manuscript;
SI – editing the manuscript;
VB and JO – critical revision and approval of the final manuscript.

References

- Ansorge, D., Godwin, R.J. 2007. The effect of tyres and a rubber track at high axle loads on soil compaction. Part 1: Single axle-studies. – *Biosystems Engineering*, 98:115–126, doi: 10.1016/J.BIOSYSTEMSENG.2007.06.005.
- Boykov, V.P., Belkovskiy, V.N. 1988. *Shiny dlya traktorov i selskokhozyaystvennykh mashin.* – Moskva: Agropromizdat (in Russian), 240 pp.

- Bulgakov, V., Adamchuk, V., Arak, M., Nadykto, V., Kyurchev, V., Olt, J. 2016. Theory of vertical oscillations and dynamic stability of combined tractor-implement unit. – *Agronomy Research*, 14(3):689–710.
- Dospehov, B.A. 1985. Method of field experience (with the basics of statistical processing research). – Moscow: Agropromizdat, 351 pp.
- Guskov, V.V., Velev, N.N., Atamanov, Y.E., Bocharov, N.F., Ksenevich, I.P., Solonskiy, A.S. 1988. Tractory: Theory. – Moscow: Mashino-stroeniye (in Russian), 376 pp.
- Janulevičius, A., Giedra, K. 2008. Tractor ballasting in field work. – *Mechanika* 73:27–34, doi: 10.1080/16484142.2005.9638012.
- Janulevičius, A., Giedra, K. 2005. Tractor ballasting in field transport work. – *Transport*, 20:146–153, doi: 10.1080/16484142.2005.9638012.
- Lovarelli, D., Fiala, M., Larsson, G. 2018. Fuel consumption and exhaust emissions during on-field tractor activity: A possible improving strategy for the environmental load of agricultural mechanisation. – *Comp. Electron. Agr.*, 151:238–248, doi: 10.1016/j.compag.2018.06.018
- Nadykto, V., Arak, M., Olt, J. 2015. Theoretical research into the frictional slipping of wheel-type propelling units taking into account the limitation of their impact on the soil. – *Agronomy Research*, 13(1):148–157.
- Pranav, P.K., Pandey, K.P. 2008. Computer simulation of ballast management for agricultural tractors. *J. Terramechanics*, 45:185–192. doi: 10.1016/J.JTERRA.2008.12.002
- Šmerda, T., Čupera, J. 2010. Tire inflation and its influence on drawbar characteristics and performance – Energetic indicators of a tractor test. – *J. Terramechanics*, 47(6):395–400, doi: 10.1016/j.jterra.2010.02.005.
- Spagnolo, R.T., Volpato, C.E.S., Barbosa, J.A., Palma, M.A.Z., Barros, M.M. 2012. Fuel consumption of a tractor in function of wear, of ballasting and tire inflation pressure. – *Eng. Agrícola*, 32:131–139, doi: 10.1590/S0100-69162012000100014.
- Taghavifar, H., Mardani, A. 2014. Effect of velocity, wheel load and multipass on soil compaction. – *J. Saudi Soc. Agric. Sci.*, 13:57–66. doi: 10.1016/j.jssas.2013.01.004.
- Wong, J.Y., Huang, W. 2006. "Wheels vs. tracks" – A fundamental evaluation from the traction perspective. – *J. Terramechanics*, 43(1):27–42, doi: 10.1016/j.jterra.2004.08.003